



Australian Government

Department of Health and Ageing

Code of Practice for the Tamper-Evident Packaging (TEP) of Therapeutic Goods

Edition 1 (June 2003)

**Published on behalf of the
Industry Government Crisis
Management Committee (IGCMC)**



TGA **THERAPEUTIC
GOODS
ADMINISTRATION**

CONTENTS

1. Preface	3
2. Introduction	4
3. Definitions	4
4. Scope	8
5. Requirements	9
5.1. Two-piece Capsules	9
5.2. Other Dosage Forms	9
6. Tamper-Evident Features	9
6.1. Film Wrappers – Transparent	10
6.2. Blister or Strip Packs	10
6.3. Bubble Packs	11
6.4. Heat Shrink Bands or Wrappers	11
6.5. Pouches, Sachets and Form Fill Seal Packs	11
6.6. Container Mouth Inner Seals	12
6.7. Tape Seals	12
6.8. Breakable Caps	12
6.9. Tear-away Caps	12
6.10. Sealed Metal Tubes	13
6.11. Sealed Plastic / Laminate Tubes	13
6.12. Cans (Both All-metal and Composite)	13
6.13. In-built Tamper-Evident Controls	13
6.14. Sealed Two-piece Capsules	14
7. Validation of TEP	14
7.1. Design	14
7.2. Specifications	14
7.3. Validation	15
7.4. In-process Testing	15
7.5. Documentation	15
8. Labelling	15
9. Useful References	16
Appendix 1 – Example Label Statements	17

1. PREFACE

As a result of the tampering crises in the consumer medicines industry in 2000, the Therapeutic Goods Administration (TGA) established an Industry Government Crisis Management Committee (IGCMC). This Committee has been active in developing strategies aimed at preventing, or minimising the effect of, similar occurrences in the future.

An immediate step taken by the IGCMC was to provide guidelines for the whole of the industry that set out the requirements for tamper-evident packaging (TEP) with a view to making the requirements mandatory over time. These guidelines were based on a guideline developed previously by, and established as, a condition of membership of the Australian Self-Medication Industry (ASMI) since the early 1980s. The resultant IGCMC guideline was adopted on a voluntary basis also by ASMI, Medicines Australia (formerly the Australian Pharmaceutical Manufacturers Association (APMA)), the Complementary Healthcare Council (CHC) and the Medical Industry Association of Australia (MIAA) in December 2000.

This Code of Practice was developed by a Subcommittee of the IGCMC to set out the mandatory requirements for tamper-evident packaging. It supercedes the December 2000 guideline and will be underpinned in legislation as a standard made under the *Therapeutic Goods Act 1989* (the Act) with the intent of it applying to all sponsors of therapeutic goods, not just those who are members of the industry associations.

The preparation of this Code of Practice has taken into account local and international developments. While it is based primarily on the requirements established in the United States of America, the Code of Practice has also considered developments in the United Kingdom, Canada and New Zealand.

If a therapeutic good falls within the scope of this Code of Practice, compliance assessment will involve determining if the sponsor of the good has selected and applied appropriate tamper-evident packaging features and validated and verified them in accordance with the Code of Practice. This is in essence an assessment of whether TEP is “present” or “absent” together with the assessment of validation records as required.

This Code of Practice is considered to represent world’s best practice and compliance with its requirements is in the interest of the community and the therapeutic goods industry alike.

This Code of Practice is current at the time of writing. Efforts will be made to revise the Code of Practice as the technology and its applications change in the field of tamper-evident packaging.

2. INTRODUCTION

This Code of Practice establishes a national requirement for tamper-evident packaging (TEP) for therapeutic goods. This requirement will improve the security of therapeutic goods supplied in Australia and will increase the likelihood that consumers will discover if a product has been tampered with.

This Code of Practice is underpinned in legislation as a standard made under the *Therapeutic Goods Act 1989* and as such sponsors have a legal obligation to comply with its provisions.

3. DEFINITIONS

'Act' means the *Therapeutic Goods Act 1989*, as amended from time to time;

'blister' means a package in which one or more dosage units are enclosed between a pre-formed tray with individual pockets and a lidding material which may be flat or shaped. The material of the tray is usually different from that of the lid. It must be cut or torn in order to access the contents;

'British Pharmacopoeia' has the same meaning as defined in subsection 3(1) of the Act

[*NOTE: the definition as at the date of this Code of Practice is as follows:

'British Pharmacopoeia' means the edition of the book of that name, including any additions or amendments, that was in effect for the purposes of the Therapeutic Goods Act 1966 immediately before the commencement of this section and, if additions or amendments of that book are made after that commencement, or new editions of that book are published after that commencement, includes those additions or amendments, or those new editions, from a day specified by the Minister by order published in the Gazette];

'child-resistant packaging' means packaging that is designed or constructed to be significantly difficult for a young child to open, or gain access to the contents of, within a reasonable time but not unduly difficult for adults to use properly, but does not mean packaging which all such children cannot open, or obtain the contents of, within a reasonable time. Child-resistant is not synonymous with child-proof;

'closure' means the portion(s) of a package that keeps the package closed. A closure may be separately identifiable or an integral component of a package;

'container' has the same meaning as defined in subsection 3(1) of the Act

* NOTE: This is the definition as at the date of this Code of Practice. For the most accurate definition, please check the current Act or Regulations.

Code of Practice for the Tamper-Evident Packaging (TEP) of Therapeutic Goods

[*NOTE: the definition as at the date of this Code of Practice is as follows:

'container' in relation to therapeutic goods, means the vessel, bottle, tube, ampoule, syringe, vial, sachet, strip pack, blister pack, wrapper, cover or other similar article that immediately covers the goods, but does not include an article intended for ingestion];

'direct to consumer' means multi-level, mail order and internet marketing;

'distinctive design' means a design which employs a characteristic such as a pattern, name, registered trade mark, logo, or picture that cannot be readily duplicated with commonly available materials or through commonly available processes;

Note: The intent of a 'distinctive design' is to inhibit the replacement of features with materials available in the general retail market. Sponsors are not necessarily required to have an individual distinctive feature for their products. Generic yet distinctive features that are not available in the general retail market are acceptable. Packaging for sterile products that incorporates the statement "Sterile if in unopened undamaged pack" or words or symbols to that effect are considered to be of distinctive design.

'label' has the same meaning as defined in subsection 3(1) of the Act

[*NOTE: the definition as at the date of this Code of Practice is as follows:

'label' in relation to therapeutic goods, means a display of printed information:
(a) on or attached to the goods; or
(b) on or attached to a container or primary pack in which the goods are supplied; or
(c) supplied with such a container or pack];

'medical device' has the same meaning as defined in section 41BD of the Act

[*NOTE: the definition as at the date of this Code of Practice is as follows:

'medical device' is:

- (a) any instrument, apparatus, appliance, material or other article (whether used alone or in combination, and including the software necessary for its proper application) intended, by the person under whose name it is or is to be supplied, to be used for human beings for the purpose of one or more of the following:
 - (i) diagnosis, prevention, monitoring, treatment or alleviation of disease;
 - (ii) diagnosis, monitoring, treatment, alleviation of or compensation for an injury or handicap;
 - (iii) investigation, replacement or modification of the anatomy or of a physiological process;

* NOTE: This is the definition as at the date of this Code of Practice. For the most accurate definition, please check the current Act or Regulations.

- (iv) control of conception;
and that does not achieve its principal intended action in or on the human body by pharmacological, immunological or metabolic means, but that may be assisted in its function by such means; or
- (b) an accessory to such an instrument, apparatus, appliance, material or other article];

‘poisons standard’ means the current Poisons Standard as defined in section 52A of the Act;

[*NOTE: the definition as at the date of this Code of Practice is as follows:

Current Poisons Standard means:

- (a) if no document has been prepared under paragraph 52D(2)(b)—the first Poisons Standard; or
- (b) otherwise—the document last prepared under that paragraph.

First Poisons Standard means the latest edition at the commencement of this Part of the document known as the *Standard for the Uniform Scheduling of Drugs and Poisons* published by the Australian Health Ministers' Advisory Council];

‘primary pack’ has the same meaning as in subsection 3(1) of the Act

[*NOTE: the definition as at the date of this Code of Practice is as follows:

‘primary pack’ in relation to therapeutic good means the complete pack in which the goods, or the goods and their container, are to be supplied to consumers];

‘Regulations’ means the *Therapeutic Goods Regulations 1990*, as amended from time to time;

‘self-selection’, is selection made by a consumer from a range of products;

‘small container’ means a container which has a capacity of 20 mL or less;

‘Sponsor’ has the same meaning as in subsection 3(1) of the Act

[*NOTE: the definition as at the date of this Code of Practice is as follows:

‘Sponsor’ in relation to therapeutic goods, means:

- (a) a person who exports, or arranges the exportation of, the goods from Australia; or

* NOTE: This is the definition as at the date of this Code of Practice. For the most accurate definition, please check the current Act or Regulations.

Code of Practice for the Tamper-Evident Packaging (TEP) of Therapeutic Goods

(b) a person who imports, or arranges the importation of, the goods into Australia; or

(c) a person who, in Australia, manufactures the goods, or arranges for another person to manufacture the goods, for supply (whether in Australia or elsewhere);

but does not include a person who:

(d) exports, imports or manufactures the goods; or

(e) arranges the exportation, importation or manufacture of the goods;

on behalf of another person who, at the time of the exportation, importation, manufacture or arrangements, is a resident of, or is carrying on business in, Australia];

'strip' means a package in which one or more dosage units are enclosed individually in a continuous strip made by bonding two layers of material together. Each layer may be of the same or different material. It must be cut or torn in order to access the contents;

'tamper-evident packaging' (TEP) means packaging that has an indicator or barrier to entry which, if breached or missing, can reasonably be expected to provide visible or audible evidence to consumers that tampering may have occurred;

'therapeutic goods' has the same meaning as in subsection 3(1) of the Act

[*NOTE: the definition as at the date of this Code of Practice is as follows:

'therapeutic goods' means goods:

(a) that are represented in any way to be, or that are, whether because of the way in which the goods are presented or for any other reason, likely to be taken to be:

(i) for therapeutic use; or

(ii) for use as an ingredient or component in the manufacture of therapeutic goods; or

(iii) for use as a container or part of a container for goods of the kind referred to in subparagraph (i) or (ii); or

(b) included in a class of goods the sole or principal use of which is, or ordinarily is, a therapeutic use or a use of a kind referred to in subparagraph (a)(ii) or (iii);

and includes medical devices and goods declared to be therapeutic goods under an order in force under section 7, but does not include:

(c) goods declared not to be therapeutic goods under an order in force under section 7; or

(d) goods in respect of which such an order is in force, being an order that declares the goods not to be therapeutic goods when used, advertised, or presented for supply in the way specified in the order

* NOTE: This is the definition as at the date of this Code of Practice. For the most accurate definition, please check the current Act or Regulations.

Code of Practice for the Tamper-Evident Packaging (TEP) of Therapeutic Goods

where the goods are used, advertised, or presented for supply in that way; or

(e) goods for which there is a prescribed standard in the Australia New Zealand Food Standards Code as defined in subsection 3(1) of the *Food Standards Australia New Zealand Act 1991*; or

(f) goods which, in Australia or New Zealand, have a tradition of use as foods for humans in the form in which they are presented];

'validation' is confirmation by examination and provision of objective evidence that the particular requirements for a specific intended use can be consistently fulfilled;

4. SCOPE

This Code of Practice applies to therapeutic goods including medical devices that are unscheduled or in Schedule 2 or Schedule 3 of the Poisons Standard which are administered transdermally, ingested orally or come into contact with the mucous membranes. Sponsors may choose to apply TEP to other therapeutic products, however, if tamper-evidence is claimed, compliance with this Code of Practice is required.

Where a product falls within the Scope of this Code of Practice, and is also the subject of a monograph in the British Pharmacopoeia that requires a "tamper-proof" container, then the product is required to comply with this Code of Practice which is sufficient to satisfy the requirement of the British Pharmacopoeia for a "tamper-proof" container.

Dentifrices, lozenges, essential oils, topical preparations for local effect and preparations in pressurised aerosol containers are exempted from the requirements of this Code of Practice. The primary packs for first-aid kits are exempted from the requirements of this Code of Practice, however, if any of the contents of first-aid kits are therapeutic goods that are unscheduled, or in Schedules 2 or 3 of the Poisons Standard, the provisions of this Code of Practice apply to those contents.

Should sponsors choose to use TEP for medical devices that are not accessible to consumers, they must use an acceptable form of packaging that will meet the Essential Principles relating to product safety outlined in the Medical Devices Regulations.

Explanatory Notes

This means that prescription products supplied only through hospitals or which are stored in a pharmacy dispensary are not required to be packaged in tamper-evident packaging.

If however, such products purport to be packaged in tamper-evident packaging then they must comply with the provisions of this Code of Practice.

Code of Practice for the Tamper-Evident Packaging (TEP) of Therapeutic Goods

Medical devices required to have tamper-evident packaging currently include products such as contact lens cleaning solutions, eye lubricants and artificial tears that can be self-selected by consumers.

Pressurised aerosol containers are considered to be inherently resistant to tampering because of their design and therefore do not require tamper-evident packaging feature.

The exemption for dentifrices, lozenges and essential oils is consistent with the current requirements set out in the Code of Federal Regulations in the United States.

A "Tamper-proof" container is described in the British Pharmacopoeia as a closed container fitted with a device that reveals irreversibly whether a container has been opened. The approach that has been taken in Australia to date is to describe such packaging as "tamper-evident" rather than "tamper-proof".

The document "TGA Approved Terminology for Medicines" may be of assistance in determining whether a particular dosage form falls within the scope.

5. REQUIREMENTS

Tamper-evident packaging must be utilised for all products to which this Code of Practice applies. The tamper-evident packaging features must be designed to remain intact, when handled in a reasonable manner, during manufacture, distribution and retail display.

A tamper-evident packaging feature must not obscure or destroy any mandatory label information.

5.1. Two-piece Capsules

A minimum of two tamper-evident features and corresponding statements on the package are required.

5.2. Other Dosage Forms

A minimum of one tamper-evident packaging feature and a corresponding statement on the package is required.

6. TAMPER-EVIDENT FEATURES

The packaging features listed below are considered to be acceptable forms of TEP provided they are validated in accordance with Clause 7.

Whilst these forms of TEP are acceptable, they should not be seen to be exclusive of other forms of TEP or to preclude technological innovation.

Code of Practice for the Tamper-Evident Packaging (TEP) of Therapeutic Goods

Tamper-evident packaging must not be regarded as replacing or obviating the need for child-resistant packaging wherever the law requires such packaging.

In selecting or developing tamper-evident packaging, consideration should be given to the special needs of some consumers such as arthritic, manually impaired or elderly persons.

Tamper-evident packaging may involve container or primary pack systems or any combination thereof.

Note: Sealed paperboard cartons such as those sealed by gluing the end flaps and / or side-seam together are not an acceptable form of tamper-evident packaging.

6.1. Film Wrappers - Transparent

A transparent film with distinctive design is wrapped securely around the entire product container ensuring the product is completely sealed and a secure tight fit is achieved.

The wrapper must be ripped or broken to gain access to the product.

Sealing of a film wrapper with overlapping end flaps is acceptable only if the ends cannot be opened and resealed without leaving visible evidence of entry.

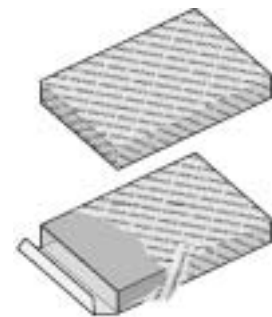

Tinted wrappers without a distinctive design are unacceptable because of the possibility that their material may be readily available as a substitute for the original wrapper.

The use of cellophane wrappers to provide tamper-evidence is not acceptable because of the possibility that their material may be readily available as a substitute for the original wrapper and the difficulty in achieving an effective weld seal.

Explanatory Note

A secure tight fit may be achieved by a heat shrink type process or other means.

6.2. Blister or Strip Packs

Individual doses (for example, capsules or tablets) are sealed in plastic and/or foil.

Blister or strip pack seals around individual compartments and the strip as a whole, must be intact and complete.

The individual compartment of the pack must be ripped or broken to gain access to the product.



Code of Practice for the Tamper-Evident Packaging (TEP) of Therapeutic Goods

The blister or strip pack materials cannot be separated or replaced without leaving visible evidence of entry.

6.3. Bubble Packs

The product and container are sealed in a plastic bubble and mounted in or on a display card.

The plastic and / or card must be ripped or broken to gain access to the product.

The backing material cannot be separated from the bubble or replaced without leaving visible evidence of entry.

Bubble pack seals must be intact and complete and sealed all the way around.



6.4. Heat Shrink Bands or Wrappers

Bands or wrappers with a distinctive design are shrunk by heat to tightly seal the union of the cap and container.

The seal must be ripped or broken to gain access to the product.

The band or wrapper cannot be removed and reapplied without visible damage.

Use of a perforated tear strip can enhance tamper evidence.

Cellulose wet shrink seals are not acceptable because of the reversible nature of these seals.

Tinted bands without a distinctive design are unacceptable because of the possibility that their material may be readily available as a substitute band or wrapper.



6.5. Pouches, Sachets and Form Fill Seal Packs

The product is enclosed in an individual pouch or sachet that must be ripped, peeled open or broken to gain access to the product.

The pouch or sachet must have a distinctive design.

Seals of the pouch or sachet cannot be separated and resealed without showing visible evidence of entry.

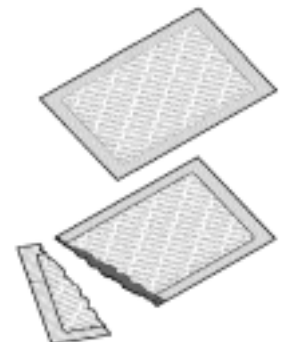

6.6. Container Mouth Inner Seals

Paper, thermal plastic, polystyrene foam, plastic film, foil, or combinations thereof, with a distinctive design is sealed to the mouth of a container under the cap.

The seal must be ripped or broken to open the container and gain access to the product.

The seals cannot be removed without showing visible evidence of entry, and once removed, seals cannot be reapplied without showing visible evidence of entry.

Seals must be intact and complete and sealed all the way around.

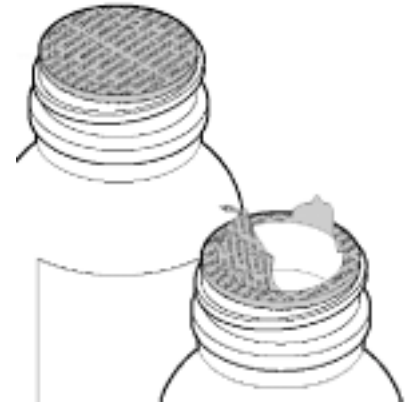

Explanatory Note

Seals applied by heat induction to containers appear to offer a higher degree of tamper-evidence than those that depend on an adhesive to create the bond.

Pressure sensitive adhesives may not offer adequate evidence of entry.

6.7. Tape Seals

Paper, foil or plastic with a distinctive design is sealed over all carton flaps or a container cap.

The seal or pack must be ripped or broken to gain access to the product.

The seals cannot be removed and reapplied, or the carton side-seam breached without showing visible evidence of entry.

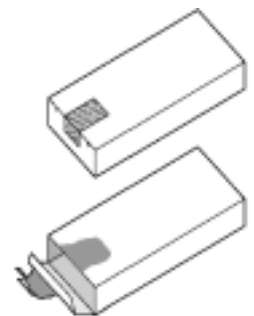

6.8. Breakable Caps

The plastic or metal cap has a portion that breaks away on opening and remains on the neck of the container.

The cap cannot be removed or reapplied in its original state.

6.9. Tear-away Caps

The plastic or metal cap has a portion that is torn away in order to allow the remainder of the cap to be removed to gain access to the product.

The tear away portion must be clearly torn or missing once the package is opened.

The cap cannot be removed or reapplied in its original state.



6.10. Sealed Metal Tubes

The lower end is sealed by folding and / or crimping.

That end must not be capable of being breached by unbending and refolding without visible evidence of entry.

The nozzle is blocked by seal or membrane. The nozzle seal or membrane must be broken or punctured to gain access to the product.

The seals cannot be removed and reapplied without showing visible evidence of entry.

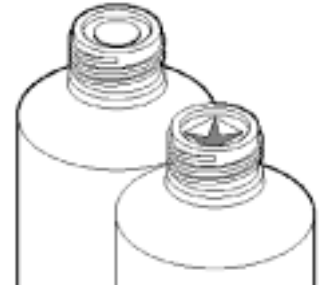

6.11. Sealed Plastic / Laminate Tubes

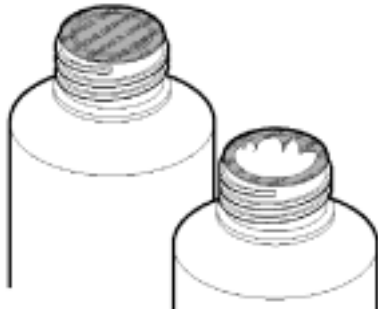

The lower end of the tube is sealed by heat sealing and crimping.

That end must not be capable of being breached without visible evidence of entry.

the product.

The nozzle is blocked by a seal, membrane or twist off top and must be broken or punctured to gain access to

6.12. Cans (Both All-metal and Composite)

The top and bottom of a can must be joined to the can walls in such a manner that they cannot be pulled apart and reassembled without visible evidence of entry.

The can cannot be reclosed without visible evidence of entry.

6.13. In-built Tamper-Evident Controls

Products such as In-Vitro Diagnostics (IVDs), which are available for use directly by consumers, may have in-built controls which demonstrate clearly that the product is unacceptable by showing a test-method failure, avoiding the potential for false results. Products incorporating such controls, which must be obvious to the user from the packaging information / instructions when trying to assess the test results, are considered as having tamper-evident controls, and for the purposes of this Code of Practice are considered to comply with the requirements without needing additional packaging or labelling.

6.14. Sealed Two-piece Capsules

Two-piece capsules are sealed such that the two halves of the capsule cannot be separated or rejoined without leaving visible evidence of entry.

Sealed two-piece capsules are required to be supplied with one additional tamper-evident feature as set out in clause 5.1. If capsules are unsealed, their packaging requires two tamper-evident features.



Note: Capsules may be sealed by means such as banding, sonic welding and sealing techniques employing solvents or low temperature heating.

7. VALIDATION OF TEP

This section provides general validation principles and requirements. It does not set out detailed requirements for all situations.

Validation of tamper-evident packaging is a total process involving the identification and control of packaging materials and processing variables.

Validation may be undertaken by the sponsor, manufacturer, component supplier or other party as appropriate, however, the onus remains with the sponsor to ensure that the TEP feature performs according to design specifications.

7.1 Design

During design of TEP, the following aspects must be considered:

- (a) Suitability of the packaging for its intended purpose;
- (b) Compatibility of the packaging components;
- (c) Compatibility of the packaging components with the packaging process;
- and
- (d) Presence of the required TEP statements on the final pack.

The tamper-evident packaging features must be designed to remain intact, when handled in a reasonable manner, during manufacture, distribution and retail display.

7.2 Specifications

In recognition of the variability of packaging components, the sponsor must ensure that clear and concise specifications are developed and agreed between the packaging material supplier and the product manufacturer.

Specifications must include functional / performance criteria and must include reference to approved engineering drawings where appropriate.

7.3 Validation

Validation must be performed in accordance with documented procedures to ensure the tamper-evident feature(s) meets the required specifications and intended use.

Validation must include the ability of the tamper-evident feature to withstand the rigours of application, handling, transport, distribution, and storage including the environment as appropriate.

The validation protocol must specify critical steps, acceptance criteria, type of validations to be conducted (eg retrospective, prospective, concurrent) and the number of process runs including sampling strategies.

Written procedures for revalidation must be in place when changes are made to manufacturing processes, packaging components or to their suppliers.

7.4 In-process Testing

Quality Control / Quality Assurance activities must be undertaken and documented at different stages of production to ensure:

- (a) Compliance of components against specifications;
- (b) In-Process testing to verify that specified criteria (as established during validation) have been met; and
- (c) Quality Assurance – documented reviews inspections and retention samples and final release for sale.

7.5 Documentation

Records of validation must be kept.

Explanatory Notes

Guidance on validation can be found in Annex 15 of the Australian Code of Good Manufacturing Practice for Medicinal Products (August 2002) as updated from time to time.

Some factors that may be considered during validation are:

- *Incoming goods – grades of materials (specifications/engineering drawings)*
- *Supplier – supplier certification*
- *Equipment – line settings, speed, temperature, pressure, dwell time, torque*

8. LABELLING

Where TEP is required by this Code of Practice, a statement must be included on the package to describe the tamper-evident packaging feature to the consumer and to

Code of Practice for the Tamper-Evident Packaging (TEP) of Therapeutic Goods

warn that the absence of, or damage to, such feature(s) at the time of purchase is an indication of possible tampering.

Appendix 1 contains examples of statements currently used in the Australian market or drawn from overseas labelling recommendations to describe tamper-evident packaging features. These or words to this effect are considered to be acceptable.

Sponsors may deviate from the statements in Appendix 1, but in doing so are encouraged to utilise performance-based labelling principles to ensure that revised statements deliver at least equivalent consumer understanding.

For products with a container and primary pack, the TEP statement must be provided on both the container and primary pack. Alternatively, the container must bear a statement alerting the consumer that the container should be inside a carton (or other primary pack) at the time of purchase.

For sachets not for individual sale, blister or strip packs and small containers, it is acceptable for the TEP statement to be included only on the primary pack.

The statement is required to be placed so that it will be unaffected if the tamper-evident feature of the package is breached or missing.

If the tamper-evident feature chosen is one that uses an identification characteristic, that characteristic is required to be referred to in the statement.

Explanatory Notes

Sponsors are not necessarily required to create an individual statement for their products. Generic statements as supplied on some packaging components by packaging material manufacturers are acceptable.

Due to the potential for paper labels to be removed and/or substituted, direct printing of the label on the container may be considered as an alternative.

9. USEFUL REFERENCES

Improving Tamper-Evident Packaging (1992), Jack L. Rosette, Technomic Publishing Company, Pennsylvania USA.

Australian Code of Good Manufacturing Practice for Medicinal Products (16 August 2002)

ISO 13485 Quality Management Systems – Medical Devices – System requirements for regulatory purposes

Appendix 1 – Example Label Statements

Tamper-Evident Feature	Suggested Wording
Film Wrappers	Do not use if film wrapper is damaged or missing
Blister or Strip Packs	Do not use if blister seal is broken Do not use if blister backing is damaged
Bubble Packs	Do not use if blister seal is broken
Heat Shrink Bands or Wrappers	Do not use if seal (around cap/under lid, etc.) is broken or missing Do not use if tape (band) around cap is damaged Band around cap must be present to ensure package security The seal over/around the cap is your assurance that the package has not been opened For your protection, this bottle has an imprinted seal around the neck
Foil, Paper, or Plastic Pouches	Do not use if pouch is torn
Bottle Mouth Inner Seals	Do not use if inner foil liner is missing or broken Bottle sealed under cap for your protection
Tape Seals	Now with tamper-evident carton seal Tape over carton flaps must be unbroken Use only if carton seal is unbroken Do not use if seals over carton ends are missing or broken
Breakable Caps	Now with tamper-evident cap seal Bottle has been opened if cap is separated Use only if cap seal is unbroken The seal on the cap is your assurance that the package has not been opened Do not use if cap seal is broken
Sealed Metal Tubes or Plastic Blind-end Heat Sealed Tubes	Do not use if foil seal at mouth of tube is broken Do not use if sealed tip is cut
Cans (Both All-Metal and Composite)	Do not use if can is damaged
In-Built Tamper-Evident Controls	Sterile if in unopened undamaged pack
Sterile Medical Devices	Sterile if in unopened undamaged pack

Note: Some of these statements may be improved by putting into the active voice e.g. “Do not use if...”.